



Please send inserts to:

GATE 2

YM Chantry Bindery

Stephenson Way

Wakefield 41 Industrial Estate

Wakefield

WF2 0XN

FAO:

Holly Lamb – Mobile: +44 (0) 7793 247 473 – +44 (0) 1924 821 603– holly.lamb@ymgroup.co.uk

Each delivery needs to be booked in prior to arrival and a booking in slot is required. Failure to do this may result in inserts being turned away.

Within the rest of this document you will find guidelines and relevant information required. If you have any queries please feel free to contact us and we will be able to help.



Insert Specifications &
Goods Acceptance Procedure
For
YM Chantry Bindery

Booking In Procedure

PRODUCT IDENTIFICATION & TRACEABILITY

This information must also appear on the delivery advice note when the load finally arrives.

- a) YM Chantry work ticket number
- b) Number of pallets to be booked in
- c) Total quantity of supplied material
- d) Publication title
- e) Publication Issue date
- f) Product type (polythene, strapping, inserts etc)
- g) Product name (Alliance & Leicester, Virgin etc)
- h) Name of haulier
- i) Any codes/regional info or relevant designation of the product or insert
- j) Number of pallets delivered and quantity per pallet marked on delivery note
- k) Number of 'chep' pallets on the delivery (if applicable)

When calling to arrange a delivery slot, the above information must be available, along with the supplementary information below.

- a) Suppliers' name & contact number
 - b) Contact name
 - c) Contact number
 - d) A separate delivery note must accompany each insert supplied for more than one magazine/issue
- If material is put into cartons, each carton must be labelled as above.
- Each pallet should have a label on both sides confirming the above information.
- YM Chantry bindery reserves the right to refuse deliveries that are non-checkable due to insufficient information.

The customer/supplier will be notified immediately, if possible of any non-conformance with the above in order that corrective action may be taken. Any delay in rectifying the non-conformance could cause a delay in the commencement of production of a job, and any liability will be the customer / suppliers responsibility and may result in cancellation of the insert.

- A sample of any inserts/onserts sent is to be placed on the outside of each pallet.
- Inserts / onserts varying in size and code must not be presented on the same pallet.

YM Chantry bindery reserves the right to refuse deliveries that are either:

- a) Non-checkable due to insufficient information or unsafe stacking/packaging.
- b) Damaged in transit
- c) Not booked in

Note: The quantities stated on all delivery notes can not be verified; therefore YM Chantry Bindery accepts no responsibility for short supply

Delivery Address for: YM Chantry Ltd

GATE 2
YM Chantry Bindery
Stephenson Way
Wakefield 41 Industrial Estate
Wakefield
WF2 0XN

Holly Lamb
Production Controller
Mobile: 07793247473
DDI: 01924 821603
Holly.Lamb@ymgroup.co.uk

Delivery Times: Mon 08:00 – Fri 17:00
Booking In Times: 09:00 – 17:00 (Mon. – Fri)

Vehicle Loading Specification

YM Chantry continually reviews its site operations both with a view to efficiency and the Health & Safety of its employees and visitors to site.

In light of ever increasing legislation governing the unloading and loading of vehicles issued by the HSE it has been concluded that YM Chantry can no longer accept goods delivered in container type trailers (Example Below)



A recent review has highlighted both the high risk of an accident to personnel involved in unloading this type container at site plus the additional time taken has resulted in the site being unable to accept deliveries in the above vehicles from 1st January 2008.

The standard specification requested by YM Chantry is as follows:-

- 7.5 tonne GVW rigid curtain sided vehicle
- 18-tonne GVW rigid curtain sided
- 44-tonne GVW articulated curtain sided vehicle
- Double-decker articulated curtain sided vehicle

(Example Below)



If you require any further information relating to the above please contact:-

Purchasing & Logistics Director
YM Chantry Ltd
Brindley Way
Wakefield 41
Wakefield
WF2 0XQ

Tel:- (01924) 829811

All vehicles should be booked in at least 24 hours prior to expected delivery time (unless arranged in advance) to receive an allocated time.

Bulk Presentation

Customers and suppliers are responsible for the way in which materials are presented. All materials are handled on high speed binding and mailing lines and it is essential that they arrive to specification, to ensure the highest levels of health and safety are not compromised.

1) All materials should be stacked on 4 way entry pallets with 4 way strapping,

NB: Products supplied using steel strapping will be refused due to Health & Safety implications.

2) All pallets to have wooden top board the same size as the base and the overall height of the pallet is not to exceed 1 metre.

3) All decks are to be covered with a solid base before loading to prevent damage to the bottom layer of material.

4) Interleaves to be placed in between each layer to aid stability and to prevent creasing and distortion.

5) All pallets to be clearly labeled.

6) Pallets should be adequately wrapped to avoid damage in transit, including corner protectors where appropriate.

Bulk Presentation Continued

7) Inserts should be bulk packed on pallets where possible to avoid excess packaging such as boxing, straps and elastic bands etc which may slow down the manufacturing process, but not to the detriment of presentation. When necessary to turn the product, a minimum of 50 per turn should apply.

8) Inserts should be stacked flush to the pallet edges. Inserts protruding from the sides will be creased or curled by the pallet wrap. Similarly, inserts not stacked to the pallet edge will cause pallets to be unstable and loads to become distorted during transportation.

9) Logs of folded sections should be pressure strapped and each log should be held with stiff non-returnable end boards, and adequate interleaving material used between layers.

Non Conforming Pallets

YM Chantry Bindery reserve the right to refuse to accept any goods that are deemed to not conform with our acceptance criteria, especially if acceptance would compromise the health and safety of any individual.

Our customer / supplier will be notified as soon as possible of any non-conformance, and timely remedial action will be sought. Any delay to production caused by this, resulting in late production of a product, will be wholly at our customer / supplier liability.

Destruction of Inserts

Due to the ever increasing number of inserts being used and the resultant storage / segregation issues this may cause, any 'overs' will be disposed of within 7 days of publication of a weekly title, and within 14 days of publication of a monthly or less frequent title.

Courier Deliveries

This information must appear on the delivery advice note when the load finally arrives.

- a) Date delivered
- b) Destination (our address)
- c) Weight
- d) Reference (should be a work ticket number where the product delivered relates to a specific job or a contact name in all other circumstances)
 - Where no work ticket number is available, the Publication Title, Publication Issue Date and Product Name **must** be included (e.g. Cosmopolitan / June / Alliance & Leicester).

e) Brief description of product contained within (e.g. inserts)

SPECIFICATION FOR THE SUPPLY OF PRINTED SECTIONS

◆ HIGH PRESSURE LOGGED SECTIONS

Identification: All sections to be labeled with job and section number on either the spine or foreedge. A black block to be printed in a different position per section on the binding lap.

Endboards: All endboards to be the same dimensions as the printed sections supplied (includes binding lap on stitched work)

E.G. 1st dimension = cut off
2nd dimension = reel width divided by 4.

+ or -2mm **tolerance on either dimension of the section size will be accepted.** (see diagram 1)

Logs: The presentation of logs on a pallet should be uniform maximising the pallet size with no overhangs and presented **SPINE DOWN** (see diagram 2).

Pallets: Standard 4-way entry non-returnable pallets 1200 x 1000 mm in good condition. Each pallet should be under layered with a substantial card or reel end to protect the first row from lat. damage. (see diagram 3)

Packaging: Each layer to be interleaved with substantial card or reel ends. Protection to be placed on all 4 corners to add to stability in transit. A top board or substantial card / reel end to protect top logs from strapping. Pallets to be strapped in both directions. Water proof swirl wrap to outer of pallet.

Label: Log labels to be placed on the same end of every log to identify section / version. Multiple versions to be colour coded (see diagram 2)

Pallet Label to contain the following info:

Work Ticket Number
Job Name
Section & pagination
Sequential Pallet Number
Quantity

◆ **HAND STACKED SECTIONS**

Identification: All sections to be labeled with job and section number on either the spine or foreedge. A black block to be printed in a different position per section on the binding lap.

Stacking: Sections to be brick stacked in turns on the pallet to minimise movement during transit. Copies to be turned in as larger amount as possible and no smaller than 150mm.

Pallets: Standard 4 way entry non-returnable pallets 1200 x 1000mm in good condition. Each pallet should be under layered with a substantial card or reel end to protect the first row from lat. damage. (see diagram 3)

Packaging: Each layer to be interleaved with substantial card or reel ends. Protection to be placed on all 4 corners to add to stability in transit. A top board or substantial card / reel end to protect top logs from strapping. Pallets to be strapped in both directions. Water proof swirl wrap to outer of pallet.

Label: Pallet Label to contain the following info:

Work Ticket Number
Job Name
Section & pagination
Sequential Pallet Number
Quantity

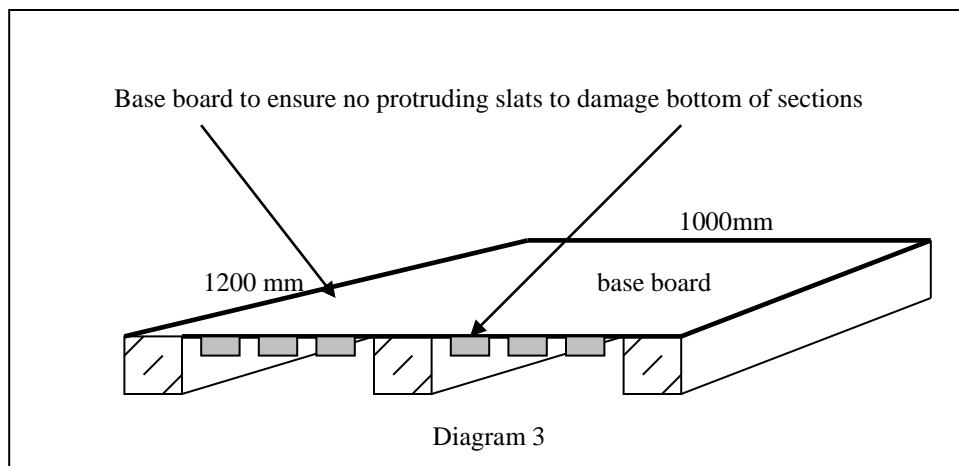
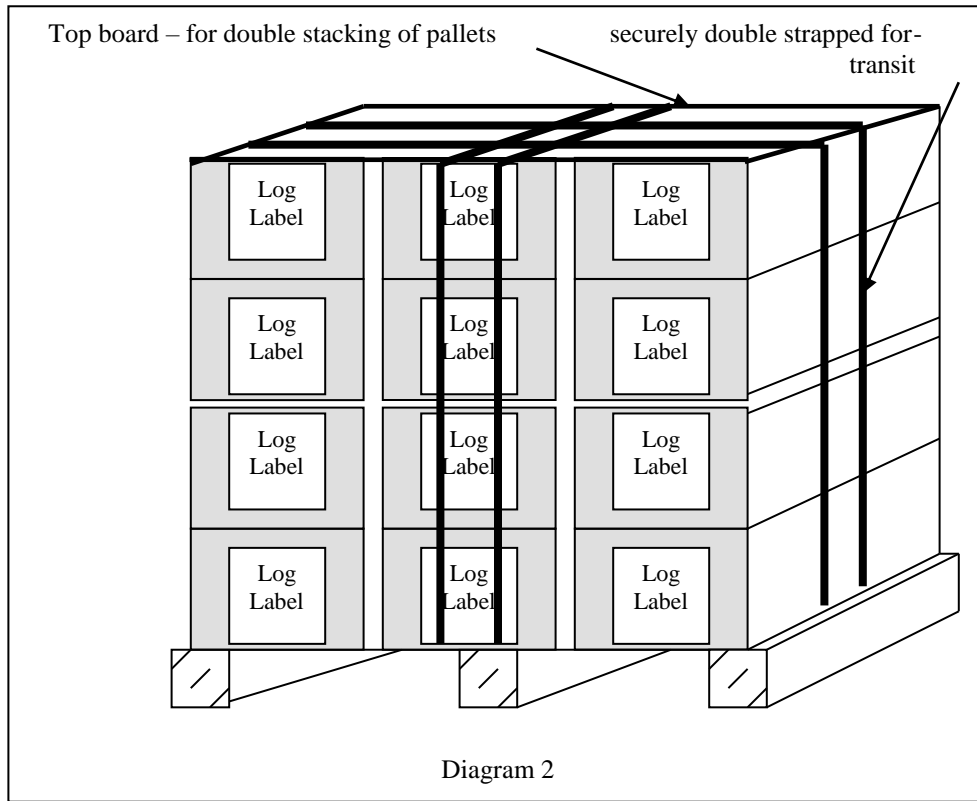
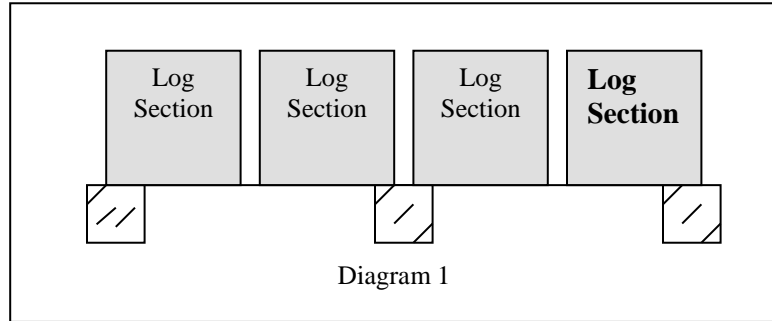

Specification for Stitched Inserts

Pagination: Minimum of 4 pages to a maximum of 32pp for saddles stitching. Gatefold or other foldouts or inserts containing foldouts must be submitted as dummies or samples for approval (before acceptance of booking)

Format: Maximum 480mm depth x 310mm wide (trimmed size)
515mm x 350mm untrimmed
Minimum sizes 148mm depth x 115mm wide.

Paper

Substances: No lighter than 100gsm for a 4 or 6pp – maximum weight 200gsm
No lighter than 70gsm for 8 pages, 32pp maximum stock weight 150gsm.
Any gatefold or other fold out should have a minimum paper substance of 100gsm. (This must be approved before acceptance of booking)

Presentation: Preferred as pressure bundled sections suitable for automatic loading up to a maximum length of 120cm, with non-returnable stiff end boards.
Stacked on non returnable pallets with consistent turns of no less than 50's, same way up and same way round, suitable for loading by hand in to high speed binding equipment

Smaller piles delivered will incur a re stacking charge of £5 per 1000 copies.

A minimum wastage allowance of 2% in excess of booked quantity should be delivered.

Position: On saddle stitched productions, a bound insert can be positioned between any two sections but half the insert will appear in the front half of the magazine and the other half will appear in the back.

Positioning of a stitched insert is at the discretion of the publisher

Specification for Bound Inserts

- Pagination:** Minimum of 2 pages. Gatefold or other foldouts or inserts containing foldouts must be submitted as dummies or samples for approval (before acceptance of booking). Specific dimensions are available on request.
- Format:** Maximum 304mm depth x 310mm wide (trimmed size)
Minimum sizes 136mm depth x 100mm wide.
- Paper Substances:** **No lighter than 90gsm for a 2pp or 4pp section**
No lighter than 75gsm for a 8pp to 16pp section
Gramages over 150gsm are subject to approval.
Any gatefold or other foldout should have a minimum paper substance of 75gsm. All foldouts must be approved before acceptance of booking.
- Presentation:** Preferred as pressure bundled sections suitable for automatic loading up to a maximum length of 120cm, with non-returnable stiff end boards.
Stacked on non returnable pallets with consistent turns of no less than 50's, same way up and same way round, suitable for loading by hand in to high speed binding equipment
- Smaller piles delivered will incur a re stacking charge of £5 per 1000 copies.*
- A minimum wastage allowance of 2% in excess of booked quantity should be delivered.
- Position:** Bound inserts can be positioned between any two sections of the magazine. They can also be positioned between the cover and first page of text subject to prior consultation **but must be a minimum of 115gsm**
- Any more than three bound inserts will be subject to slow running costs.**
- A maximum of six bound inserts are allowed subject to approval and machine availability**

Specification for Loose Inserts Into Bound And Stitched Titles

Pagination: From a single sheet to a maximum of 64 pages with a single spine (no concertina folds or other loose edges on edge to be fed into magazine).

The total number of insert pages must not exceed 100 in any one title

Format: Minimum size: 148mm depth x 105*mm wide
Maximum Size: 275mm depth x 280mm wide
Loose inserts must be smaller than the magazine they are being inserted into. They must be 20mm smaller on the head to tail measurement and 30mm smaller on the spine to foredge measurement. The spine to foredge measurement can be reduced to 20mm for some inserts but only after samples have been submitted and approved.

NB: 2pp inserts with a lip – the lip should be half the size from the fold to back edge.

Minimum Thickness 2 page 90gsm

Maximum Thickness 3mm.

Paper

Substances: No lighter than 90gsm for a single Leaf
No lighter than 70gsm for a 4pp or 6pp insert
No lighter than 48gsm for an 8pp to 64pp insert
No greater than 80 gsm for an 8pp to 48pp insert
No greater than 60gsm for a 64pp insert.

Presentation: Preferred as pressure bundled sections suitable for automatic loading up to a maximum of 120cm long, with no returnable stiff end boards. Stacked on non returnable pallets with consistent turns of no less than 100's, same way up and same way round, suitable for loading by hand in to high speed binding equipment.

If onserts are unable to be bulked stacked due to size and shape, they should be suitably packed in easy to open cartons before palletising. Bundles must not have any film wrap or elastic bands.

Cartons used should be to the correct size to prevent transit damage

Smaller piles delivered will incur a re stacking charge of £5 per 1000 copies.

A minimum wastage allowance of 2% in excess of booked quantity should be delivered

N.B Due to machine limitations our target efficiency for loose inserts and tip ons is 95%. However, we can arrange for 100% insertion / tip on by utilising hand finishing techniques.

Saddle Stitched & Perfect Bound Glued Card Specification

PLEASE NOTE: Facility only available to advertisers taking page space to which the card is to be glued.
The page to which the card is to be glued can only be the first page of any section when knocked to the head or the last page if knocked to the foot.

Pagination: Normally a single sheet. Alternatives will be considered, but dummies or samples are to be submitted for approval and permission given before acceptance of booking.

Format

Minimum (Stitching line): 60mm x 80mm

Minimum (Perfect binder): 100mm x 60mm

Maximum (Stitching line): 210mm x 210mm square cut dimensions – cards involving other shapes to be submitted as dummies or samples for approval before acceptance of booking *but as a guide*, at least 2 straight cut edges at right angles *must* conform to these format dimensions

Maximum (Perfect binder): 290mm x 225mm

Paper substances: No lighter than 140gsm (or 180 microns thickness, which ever is lowest) and no heavier than 250gsm.

Presentations: Stacked on non-returnable pallets or packed easily into boxes. Cards to be presented whether on boxes or pallets uniformly, i.e. the same way round and the same way up and must not vary in size. A wastage allowance of 1% in excess of the booked quantity should be delivered.

Positioning: See attached positional guide. A layout indicating the position must be supplied. This must also show which side of the card is to be glued. A tolerance of +/- 4mm to the selected position must be allowed for variations in the production run.

Note: A glued card can be placed on the first page of text. However, this will cause trimming and creasing problems on the cover when the book is trimmed. Glued cards are best placed between sections to produce an aesthetically pleasing final product.

Note: A PIRA test certificate for all glued sachets should be forwarded to the relevant CCE before confirmation of acceptance.

A maximum of three tip ons per issue consisting of two sachets and one card which are all subject to approval

Specification for Static Nailing on Perfect Binding

- Pagination:** Maximum pagination of insert must be no more than 6 pages.
- Format:** **Minimum** size = 140mm x 100mm
Maximum size = trim size less: 80mm head – tail, 60mm spine – foreedge
- Paper substances:** **Minimum** substrate = 115gsm for single leaf, 80gsm 4pp / 6pp.
Maximum substrate = 170gsm for single leaf, 130gsm 4pp / 6pp
- Presentations:** Preferred as pressure bundled sections suitable for automatic loading up to a maximum of 120cm long, with no returnable stiff end boards. Stacked on non returnable pallets with consistent turns of no less than 100's, same way up and same way round, suitable for loading by hand in to high speed binding equipment..
- Positioning:** Must be positioned between sections i.e. can not be positioned I.F.C / I.B.C.

Cartons used should be to the correct size to prevent transit damage

Smaller piles delivered will incur a re stacking charge of £5 per 1000 copies.

A minimum wastage allowance of 2% in excess of booked quantity should be delivered

N.B Due to machine limitations our target efficiency for loose inserts and tip ons is 95%. However, we can arrange for 100% insertion / tip on by utilising hand finishing techniques.

Specification for 'Magna Strip' Inserts in Perfect Binding

Pagination: Maximum pagination for magna-strip inserts is 36pp, including cover

Only one magna strip per issue which must be approved in conjunction with other bound inserts. Insertion costs to be agreed

Format: Maximum spine to foredge size for magna-strip inserts in A4 product is 198mm, plus 3mm bleed.

It is not advisable to trim a Magnastrip product with the magazines foredge. The overall size of an insert plus Magnastrip must meet the current bound insert specification. Magna Strips can be applied to any insert with one straight closed edge; multiple edge products such as concertina folds are not acceptable.

A total of 15mm (inclusive of 3.0mm grind-off) of the magna-strip width is required to bind into the spine of the magazine. A further 15mm of magna-strip width is recommended to securely attach the insert.

A minimum of 5mm trim allowance must be allowed for inserts smaller than the finished product size.

Paper substances: The magna-strip itself must be within the following range; >150gsm, <230gsm

The minimum recommended weight of paper for insertion is 90gsm. There is no maximum weight of paper within reason but the maximum overall weight of a maximum size single insert as supplied untrimmed must not exceed 116gsm.

Presentation: Magna Strips must be supplied in PAL boxes, layered with card and dividers. They must be presented the same way up and same way round and must not vary in size. A wastage allowance of 2% in excess of booked quantity should be delivered.

Magna Strip by their nature are usually bulky and can only be hand-fed onto the gathering line, consequently this will have an effect on the running speed of the whole binding line. In some cases, this will incur extra charges. The bulk of an insert 16 or more pages may affect the trimming of the magazine and may cause 'nicking' of the text pages.

Bundles should be supplied >100s, <200s turned in 50s or 100s for ease of handling.

Positioning: Must be positioned between sections i.e. can not be positioned I.F.C / I.B.C. Laminated or UV coated stock may not adhere securely to magna-strips. Customers should satisfy themselves of compatibility before confirming an order.

Specification for Post It Notes

- Pagination:** A single sheet. can be either portrait or landscape reading.
- Placement:** First page of any text section 16 pages in thickness or above.
- Insertion Rate:** 100% insertion rate can not be guaranteed, as the line is not stopped to change reels. We estimate a 95% insertion.
- Presentation:** Reels to be stacked on non-returnable pallets or packed easily into boxes. A wastage allowance of 1% in excess of the booked quantity should be delivered.
- Internal diameter of core supplied must be 76mm.
External maximum diameter of reel is 310mm.
- Positioning:** Positioning varies depending on the requirement for Perfect Bound or Saddle stitched products.
As a general rule, a post-it can be positioned anywhere to the right of center of a page on a perfect bound text section. For all design and positional variations, please contact your relevant Customer Care Executive.
A layout indicating the position must be supplied. A tolerance of + or – 5mm to the selected position must be allowed for variations in the production run.

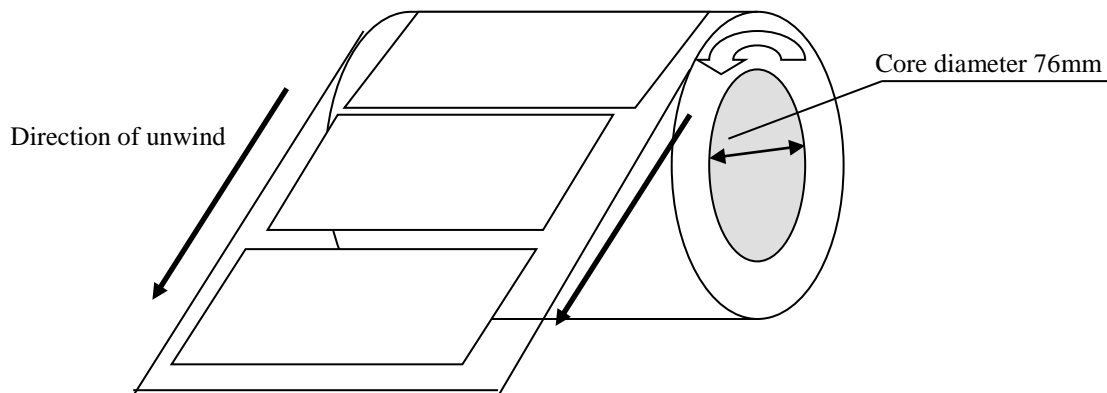

Diagram 1